

SPECIFICATION

CONTACT RATING : 15A 250VAC (CSA,UL)
10A 250VAC (N S D FI, VDE)

APPROVAL :UL CERTIFICATE NO.: E200241

CSA CERTIFICATE NO.: LR77849

DEMKO CERTIFICATE NO.: 308050

SEMKO CERTIFICATE NO.: 9833192/01

NEMKO CERTIFICATE NO.: P98102225

FIMKO CERTIFICATE NO.: FI11665

VDE CERTIFICATE NO.: 115886

3C CERTIFICATE NO.: 2003010204030912

INITIAL CONTACT RESISTANCE: 30mΩ (MAX)

INSULATION RESISTANCE: 100MΩ (MIN) 500 VDC

TERMINAL TO TERMINAL DIELECTRIC

WITHSTAND VOLTAGE : 2000VAC/1 MINUTE

MATERIAL USED MUST BE COMPLY WITH BQI-0555 .

solteam
文件管制
發行章
APR.28.2005

TOLERANCES UNLESS OTHERWISE 未指定容許差尺寸之公差	
BASIC DIMENSIONS TOLERANCES	
UP TO 10 (10 以下)	±0.3
ABOVE 10 TO 100(10~100)	±0.5
ABOVE 100 (100 以上)	±0.8
ANGULAR DIMENSIONS(角度)	±5°

崧騰企業股份有限公司 SOLTEAM ELECTRONICS CO.,LTD

核准 APPROVED BY	日期 DATE	040607	投影法 PROJECT	單位 DIMENSION UNIT	mm
校對 CHECKED BY	日期 DATE	040607	比例 SCALE	機型 PART NAME	INLET SOCKET
繪圖 DRAWN BY	日期 DATE	040607	路徑 DWG NO	型號 PART NO	ST-01-BF9
NO.	DATE	REVISION DESCRIPTION	ISSUE	REVISE	APPROVED

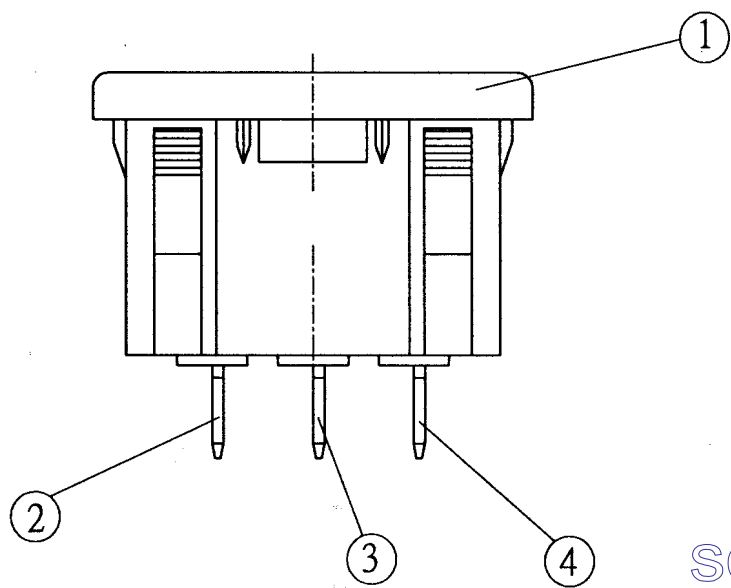

NO	PART NAME	MATERIAL
1.	Body	Nylon 66 Type
2.	Terminal	Tin Plated Brass
3.	Terminal	Tin Plated Brass
4.	Terminal	Tin Plated Brass

solteam
文件管制
發行章
APR.28.2005

崧騰企業股份有限公司 SOLTEAM ELECTRONICS CO.,LTD

核准 APPROVED BY	日期 DATE	040607	投影法 PROJECT		單位 DIMENSION UNIT	mm
校對 CHECKED BY	日期 DATE	040607	比例 SCALE	2:1	機型 PART NAME	INLET SOCKET
繪圖 DRAWN BY	日期 DATE	040607	路徑 DWG NO	EA成品圖ST	型號 PART NO	ST-01-BF9
NO.	DATE	REVISION DESCRIPTION	ISSUE	REVISE	APPROVED	