

NO	PART NAME	MATERIAL	Q'TY
1.	Body	Nylon 66	1
2.	Insert Pin	Nickel Plated Brass	3
3.	Terminal	Tin Plated Brass	3

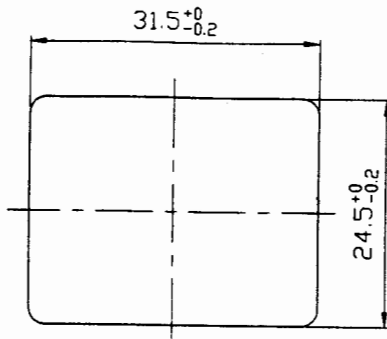

松騰企業股份有限公司 SOLTEAM ELECTRONICS CO.,LTD

△					核准	李碩	日期	060102	投影法	第一角	單位	DIMENSION UNIT	mm
△					校對	李碩	日期	060102	比例	2:1	機型	INLET SOCKET	
△	051228	VDE CERTIFICATE NO: 115886=>40015691.	AI	溫小燕	李碩	繪圖	溫小燕	日期	020128	電腦碼	5401-0111-0054	型號	ST-01J-BP
NO.	DATE	REVISION DESCRIPTION	ISSUE	REVISE	APPROVED	DRAWN BY	DATE	DATE	ERP NO	PART NO			

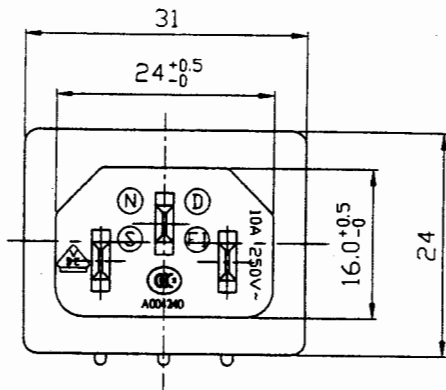

PANEL CUT-OUT

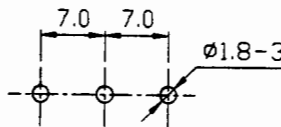
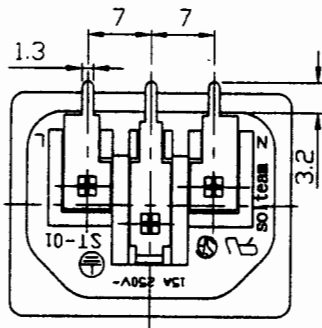
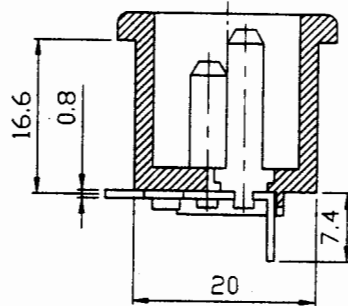
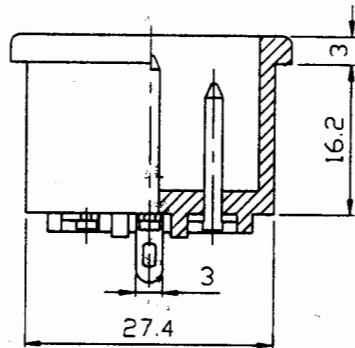

PCB LAYOUT

SPECIFICATION

CONTACT RATING : 15A 250VAC (CSA,UL)  
10A 250VAC (N S D FI),VDE)

APPROVAL :UL CERTIFICATE NO: E200241

CSA CERTIFICATE NO: LR77849

DEMKO CERTIFICATE NO: 308050

SEMKO CERTIFICATE NO: 9833192/01

NEMKO CERTIFICATE NO: P98102225

FIMKO CERTIFICATE NO: FI11665

△ VDE CERTIFICATE NO: 40015691

INITIAL CONTACT RESISTANCE: 30mΩ (MAX)

INITIAL INSULATION RESISTANCE: 100MΩ (MIN) 500 VDC

INITIAL WITHSTAND VOLTAGE:

PLEASE REFERENCE TEST SPECIFICATION-3.3

MATERIAL USED MUST BE COMPLY WITH BQI-0555 .



TOLERANCES UNLESS OTHERWISE 未指定容許差尺寸之公差	
BASIC DIMENSIONS TOLERANCES	
UP TO 10 (10 以下)	±0.1
ABOVE 10 TO 100(10-100)	±0.2
ABOVE 100 (100 以上)	±0.3
ANGULAR DIMENSIONS(角度)	±0.5

崧騰企業股份有限公司

SOLTEAM ELECTRONICS CO.,LTD

△						核准 APPROVED BY	李碩	日期 DATE	060102	投影法 PROJECT		單位 DIMENSION UNIT	mm
△						校對 CHECKED BY	李碩	日期 DATE	060902	比例 SCALE	1.5:1	機型 PART NAME	INLET SOCKET
△	051228	VDE CERTIFICATE NO: 115886=>40015691.	AI	圖小	李碩	繪圖 DRAWN BY	圖小	日期 DATE	020128	電腦碼 ERP NO	5401-0111-0054	型號 PART NO	ST-01J-BP
NO.	DATE	REVISION DESCRIPTION	ISSUE	REVISE	APPROVED								