

THICKNESS:
0.8-1.2t(X=20.3)
1.3-2.0t(X=20.5)

SPECIFICATION

CONTACT RATING : 15A 250VAC (CSA,UL)
10A 250VAC (N S D FI, VDE)

APPROVAL :UL CERTIFICATE NO.: E200241

CSA CERTIFICATE NO.: LR77849
DEMKO CERTIFICATE NO.: 308050
SEMKO CERTIFICATE NO.: 9833192/01
NEMKO CERTIFICATE NO.: P98102225
FIMKO CERTIFICATE NO.: FI 11665

VDE CERTIFICATE NO.: 40015691
3C CERTIFICATE NO.: 2003010204030912

INITIAL CONTACT RESISTANCE: 30mΩ (MAX)
INSULATION RESISTANCE: 100MΩ (MIN) 500 VDC
INITIAL WITHSTAND VOLTAGE:
PLEASE REFERENCE TEST SPECIFICATION-3.3
MATERIAL USED MUST BE COMPLY WITH BQI-0555.

PANEL CUT-OUT

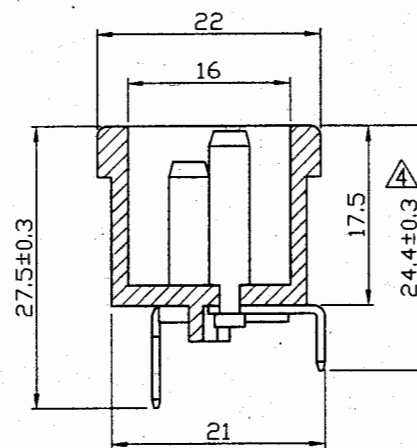
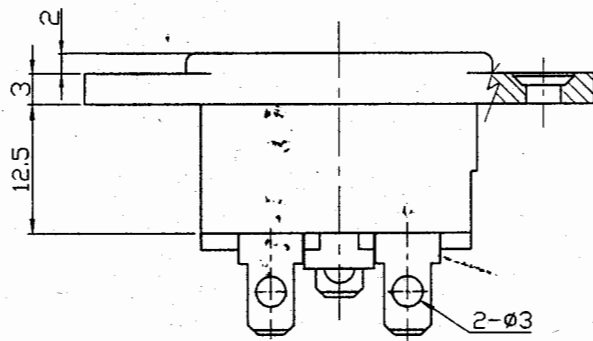

A - A SECTION

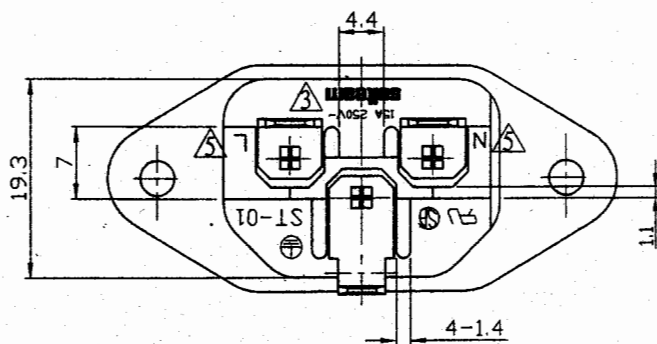

TOLERANCES UNLESS OTHERWISE 未指定容許差尺寸之公差	
BASIC DIMENSIONS TOLERANCES	
UP TO 10 (10 以下)	±0.3
ABOVE 10 TO 100(10-100)	±0.5
ABOVE 100 (100 以上)	±0.8
ANGULAR DIMENSIONS(角度)	±5°



崧騰企業股份有限公司 SOLTEAM ELECTRONICS CO.,LTD

核准 APPROVED BY	日期 DATE	060629	投影法 PROJECT	單位 DIMENSION UNIT	mm
校對 CHECKED BY	日期 DATE	060629	比例 SCALE	機型 PART NAME	INLET SOCKET
繪圖 DRAWN BY	日期 DATE	020103	路徑 DWG NO	型號 PART NO	ST-01M-BF3
NO.	DATE	REVISION DESCRIPTION	ISSUE	REVISE	APPROVED

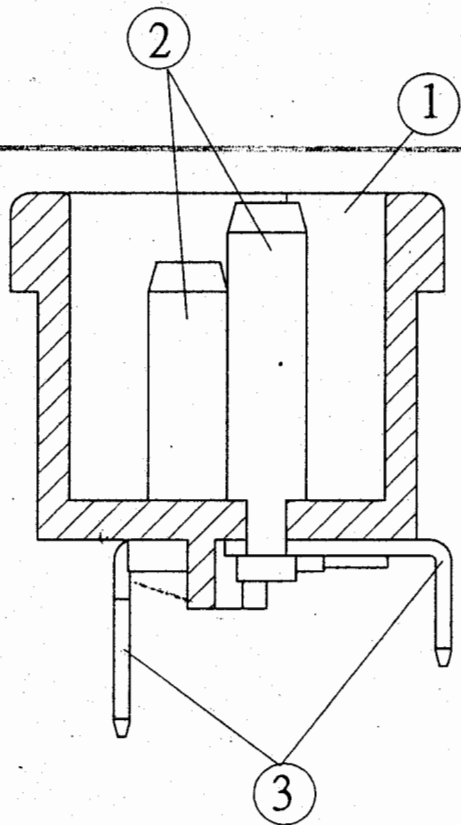

NO.	PART NAME	MATERIAL
1	Body	PBT
2	Insert Pin	Nickel Plated Bronze
3	Terminal	Tin Plated Brass

崧騰企業股份有限公司 SOLTEAM ELECTRONICS CO.,LTD

核准	日期	060627	投影法	第一角	單位	DIMENSION UNIT mm	
校對	日期	060629	比例	1:1	機型	INLET SOCKET	
繪圖	日期	020103	路徑	E:\成品圖\ST01\	型號	ST-01M-BF3	
NO.	DATE	REVISION DESCRIPTION	ISSUE	REVISE	APPROVED		
△	060620	MODIFY MATERIAL LIST.	A7				
△	051226	VDE CERTIFICATE NO.: 115886=>40015691.	A6	溫小燕 邱瑞榮			