

SPECIFICATION

Contact Rating: 12A 125/250VAC
 10(1)A 250VAC~μT85
 Contact Resistance: 50mΩ (max) initial
 Insulation Resistance: 500MΩ (min) 500VDC
 Dielectric Strength: 2000VAC/1 minute
 Electrical Life: 300 cycles
 Operation Force: 500+/-200g

SERIES NUMBER: EV-12B



PART NUMBERING SYSTEM

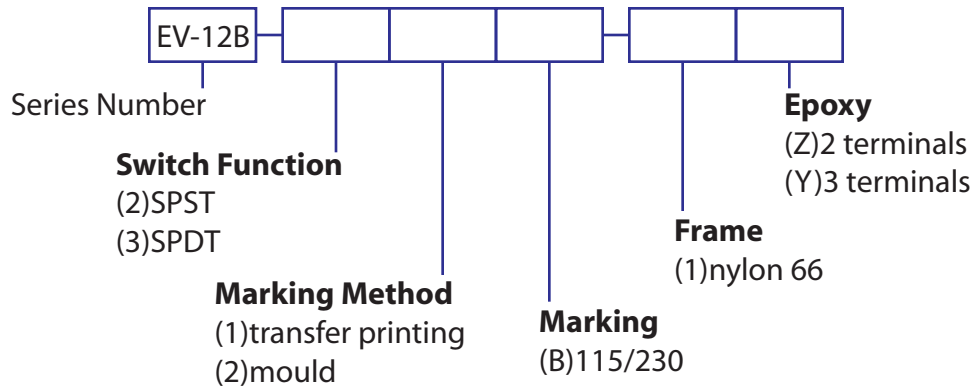

DIMENSIONS(mm)

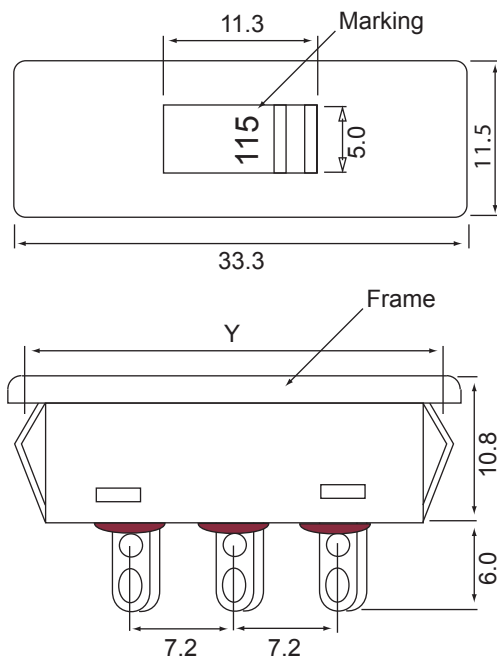

MOUNTING HOLE DIMENSIONS		
Panel Thickness	Y	X
0.80(21SWG)	29.75-29.85	10.85-10.95
0.90(20SWG)	29.75-29.85	10.85-10.95
1.20(18SWG)	29.75-29.85	10.85-10.95
1.63(16SWG)	30.15-30.25	10.85-10.95
2.00(14SWG)	30.35-30.45	10.85-10.95
2.50(12SWG)	30.55-30.65	10.85-10.95

